

## **Fiber-optic communication links suitable for on-board use in modern aircraft**

Hung Nguyen<sup>a</sup>, Duc Ngo<sup>a</sup>, Mohammed Atiquzzaman<sup>b</sup>, James Sluss<sup>c</sup>, Jr., Filip Slaveski<sup>c</sup>,  
Mohammad F. Alam<sup>d</sup>

<sup>a</sup>Antenna, Microwave, and Optical Systems Branch, NASA Glenn Research Center, 21000  
Brookpark Rd., Cleveland, OH, USA 44135

<sup>b</sup>School of Computer Science, <sup>c</sup>School of Electrical & Computer Engineering, University of  
Oklahoma, 1000 Asp Ave., Norman, OK, USA 73019

<sup>d</sup>Agere Systems, 1110 American Parkway NE, Allentown, PA, USA

### **ABSTRACT**

The role of the Advanced Air Transportation Technologies program undertaken at the NASA Glenn Research Centers has been focused mainly on the improvement of air transportation safety, with particular emphasis on air transportation communication systems in on-board aircraft. The conventional solutions for digital optical communications systems specifically designed for local/metro area networks are, unfortunately, not capable of transporting the microwave and millimeter RF signals used in avionics systems. Optical networks capable of transporting RF signals are substantially different from the standard digital optical communications systems. The objective of this paper is to identify a number of different communication link architectures for RF/fiber optic transmission using a single backbone fiber for carrying VHF and UHF RF signals in the aircraft.

To support these architectures, two approaches derived from both hybrid RF-optical and all-optical processing methodologies are discussed with single and multiple antennas for explicitly transporting VHF and UHF signals, while the relative merits and demerits of each architecture are also addressed. Furthermore, the experimental results of wavelength division multiplexing (WDM) link architecture from our test-bed platform, configured for aircraft environment to support simultaneous transmission of multiple RF signals over a single optical fiber, exhibit no appreciable signal degradation at wavelengths of both 1330 and 1550 nm, respectively. Our measurements of signal to noise ratio carried out for the transmission of FM and AM analog modulated signals at these wavelengths indicate that WDM is a fiber optic technology which is potentially suitable for avionics applications.

### **1. INTRODUCTION**

While a large number of system components and antennas currently operate on-board modern aircraft with multiple radio-frequency communications in microwave and millimeter-wave frequencies, the potential drawbacks of interconnecting these systems in traditional ways suffer from a tremendous expansion of coaxial RF cables [1-4]. The effect inevitably leads to more weight in an aircraft and also produces more electromagnetic interference, which can affect the operational performance of these RF systems installed in aircraft. In most cases, due to bundled RF cables, electromagnetic interference in aircraft may interfere with each other's operation, a result causing a dangerous situation for navigation and control management. As a result, the reduction of massive cables in the aircraft becomes essential if more fuel-efficient operation and enhanced safety conditions are to be achieved [5-7].

Coaxial cable has long been deployed in aircraft to transport radio frequency (RF) signals between antennas and electronic equipment. But, RF coaxial cable is lossy, limits the signal bandwidth, and also adds considerable weight. In addition, corrosion at cable connections can be a problem for aircraft that operate in coastal environments, as such corrosion can lead to increased susceptibility to electromagnetic interference (EMI)[8-9].

Considering other alternatives to replacement of RF coaxial cables, optical fiber has many advantages over RF cable, most notably lower loss, larger bandwidth, and immunity to EMI. Since optical fiber is typically composed of glass, and fiber connectors are composed of ceramics and plastics, corrosion is typically not a problem. In addition, the relative small size and low weight of optical fiber as compared to coaxial cable makes it well-suited for avionics applications where space and weight savings are a sought after premium.

## 2. RF/OPTICAL DISTRIBUTION NETWORKS FOR SINGLE VHF/UHF ANTENNA

We will examine a number of architectures associated with VHF/UHF optical network systems that are capable of transporting RF signals from a single antenna to all electronic components assigned in different areas located in the aircraft, i.e., cockpit, passengers, controller, etc. Figure 1 shows the concept of this architecture in a block diagram that consists of essential components, such as a single backbone optical bus, protection optical line, user access, and a single VHF or UHF-band antenna. Such antenna can be mounted outside of the aircraft to receive RF signals from either LEO satellites or ground stations. Moreover, each system can readily accommodate different formats of data information such as voice, video, and messages formatted in ATM, SHD, IP, etc., to be transported over a single optical bus for entertainment and business purpose in an aircraft.

Most importantly, since highly reliable networking systems are highly desirable in aircraft, in our design, we consider the incorporation of a protection switching unit into each node of the system to guard against failure of the backbone optical bus. For instance, when failure in this backbone bus is detected, optical signals from this backbone bus will reroute data to the protection optical line by means of optical switching units, mostly located near each node. Also, such protection units will have to include the erbium-doped fiber amplifier located at the output of the switching unit on the protection optical line, so that stabilization against slow fluctuations of the optical power on backbone fiber can be achieved [10-11]. We will address below two aspects of networking architectures that feature both approaches of RF/optical and all-optical architectures, providing VHF and UHF signals to electronic components on aircraft that use only optical fiber as a backbone bus for carrying digital data.

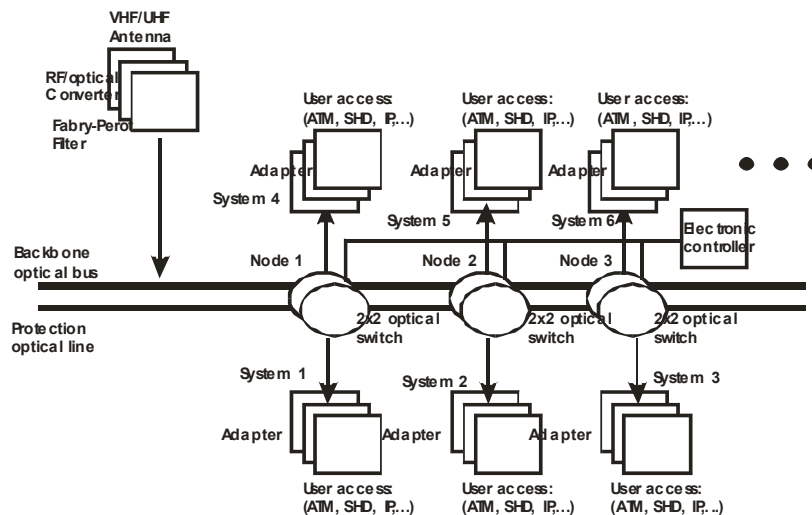

Figure 1: Concept architecture of RF/Optical distribution network for a single antenna at VHF/UHF -band frequency. (ATM: asynchronous transfer mode; SDH: synchronous digital hierarchy; IP: internet protocol )

### 2.1. RF/Optical Distribution Networks Employing RF Processing Methodology

In this RF/optical distribution approach, when an RF signal is extracted from the receiving antenna, it is converted into an optical signal which is modulated by either using direct or indirect modulation of the semiconductor source. This process in fact produces a modulated optical carrier which is then launched into the backbone optical fiber by means of a directional coupler. Also, such a backbone fiber that is to be installed in an aircraft has to be properly packaged into a cable which is different from the ones installed under the ground for local area network applications. On the backbone bus, each node is implemented with a combination of optical/RF converter and RF/splitter to transform the optical carrier into an RF signal, before rerouting it to electronic components or System 1, as shown in Figure 2. The remaining optical carrier will then continue its path to the next node in order to deliver RF signal to the next System 2 with the same process as described for System 1.

There are two approaches suitable for implementing these nodes. As in the first approach, when the optical carrier first enters a node from the RF/optical converter at the antenna, as illustrated in Figure 3A, this optical carrier is converted into RF signal so that routing RF signal to System 1 can be achieved in the electronic domain by using the controller and RF splitter unit. After that, the RF signal is transformed back into the optical carrier in order to launch the optical carrier back into the backbone optical bus. Moving to the next node, the procedure of RF distribution to System 2 will take place using the same process as stated for System 1.

The solution of this approach is simple from both installation and maintenance aspects, and demands only one optical fiber that runs from the tail of the aircraft to the cockpit. However, since each node requires a transceiver unit for performance of optical/RF conversion, the cost of the transceivers may become significantly high if more nodes need to be added to the architecture.

From the previous approach of routing the signal by using the electronic domain, the next alternative approach will rely on an optical splitter so that the RF signal to be routed to each system will be done in the optical domain rather than the RF domain. In this case, each node will use a single optical splitter to separate the optical carrier into two or more equal power fractions, depending on the number of electronic components or users to which it must be distributed. Each fraction is then transmitted to the optical/RF converter before transporting to the System 1. Thus, the main optical power of the optical splitter then taps into the backbone fiber, which will continually travel down to the next node, and System 2 will extract the RF signal from the nearest node using the same process described in System 1, as illustrated in Figure 3B.

This solution has an advantage since there are no transceivers required to implement each node in order to route the RF signal. While all the signal routing is done optically, by using an optical splitter it will allow not only the flexibility of the rerouting process between node and system, but also the simplicity of the network architecture, requiring no electronic controllers as well as RF converters.

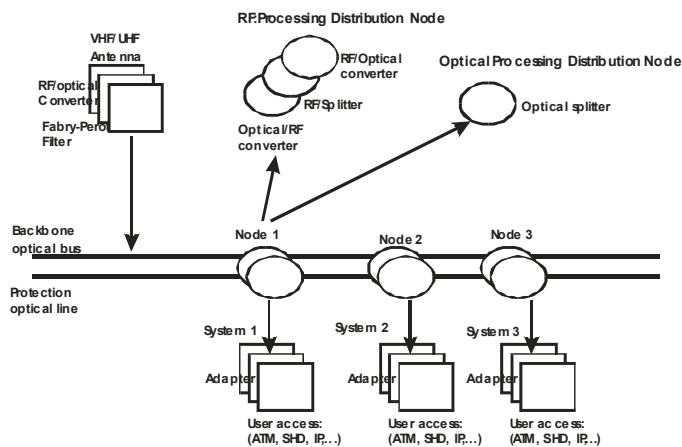

Figure 2: An architecture of RF/Optical distribution network employing both RF and optical processing distribution nodes for single antenna.

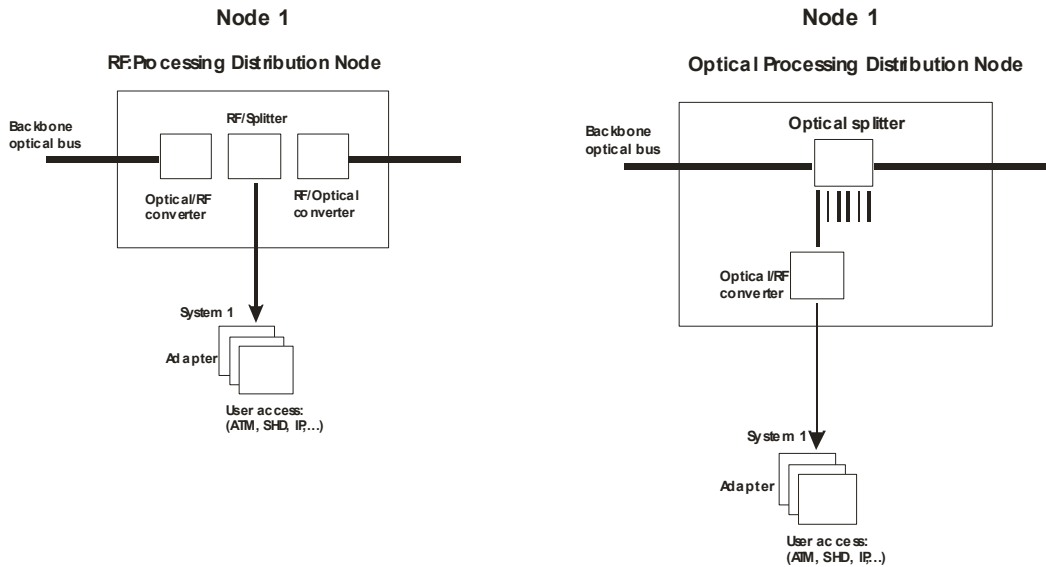

Figure 3 (A): First approach - Detailed description of each node with combination of optical/RF converter, RF splitter, and RF/optical converter for RF processing distribution method. (B) Second approach - Detailed description of each node with combination of optical splitter and optical/RF converter for optical processing distribution method.

## 2.2. Microwave/Optical Distribution Networks Employing Optical Processing Methodology

In general, for an on-board optical networking system it is preferable to consider the Passive Optical Networking (PON) architecture based on optical splitter technology. The biggest advantage of this architecture is that there is no requirement of electronic switching unit for re-routing the signal on each node of the backbone optical bus. Because PON can accommodate Asynchronous Transfer Mode (ATM), synchronous digital hierarchy (SDH), Internet Protocol (IP), and many other data formats, it also has the capability of achieving very high bandwidth up to 155 Mbps or more over a single fiber. Its distinctive feature is well-suited to transporting data, voice and image to hundreds of users in an aircraft at a considerably high-speed.

In this architecture, the optical splitter is a main component for the distribution of RF signals from the backbone fiber to all the systems in an on-board aircraft, as illustrated in Figure 4. Although only two optical splitters shown in this figure are deployed on the backbone fiber, more splitters can be implemented along the fiber depending on a number of systems to which the RF signals need to be transported. Thus, Figure 4 just represents another optical architecture solution for the problem shown in Figure 1.

Using a single RF/optical converter, an RF signal received from an antenna can be transformed into a modulated optical carrier before being tapped into the backbone optical bus by a directional coupler. In this case, only a single wavelength is required to carry the RF signal over the fiber, although any wavelength in the range 1330 – 1550 nm is preferable due to the inherent low transmission loss of optical fiber. On the backbone optical bus, two directional couplers are also used to extract the modulated optical carrier and then deliver it to each optical splitter in which the distribution can take place, as shown in Figure 4. But a choice of a one-to-four or one-to-eight optical splitter in each node depends on the number of systems in which the RF signal is required to be transported. In some cases, where the number of data distribution is high, insertion of amplification in the network may be required, and it can be achieved in either the optical or RF domain. First, in the case of the RF domain, each RF amplifier will have to be implemented at the output of the optical/RF converter, but in the optical domain, only one optical amplifier is required along the path between the backbone optical fiber and optical splitter. All of this amplification will serve as a compensation for signal loss caused by the optical splitter illustrated in Figure 5. However, the former method of using a single optical amplifier tends to be highly preferable since it contributes to less maintenance and reduced weight due to component aspects, particularly when this network is installed in an on-board aircraft.

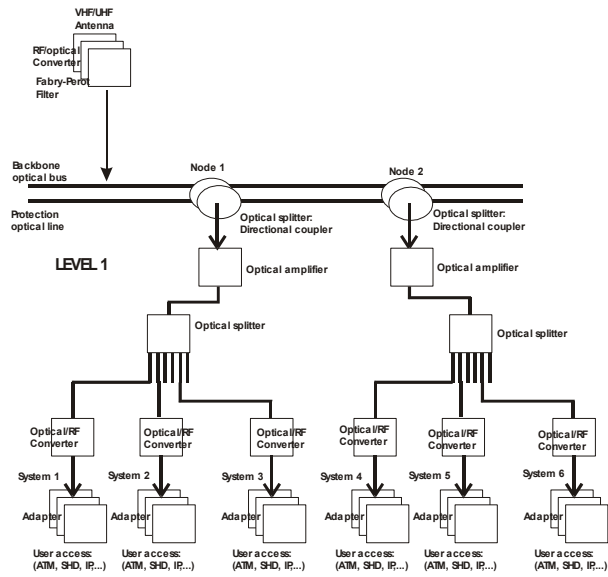

Figure 4: Architecture of all-optical approach based on passive optical networking (PON) method for RF/optical distribution networking applications.

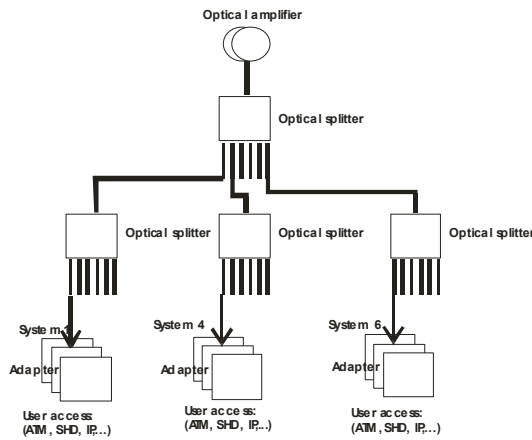

Figure 5: Detailed structure of level 1 from an architecture of all-optical approach based on passive optical networking (PON) method shown in figure 4.

### 3. OPTICAL DISTRIBUTION NETWORK FOR MULTIPLE ANTENNAS

This section will identify the architecture that provides the capability to transport multiple VHF/UHF signals from various antennas to the systems on-board the aircraft using only a single backbone fiber, as illustrated in Figure 6 with four antenna and six receiving systems. In addition, we will also focus our investigation on two approaches, RF/optical and all-optical, which will be discussed separately in the following sections.

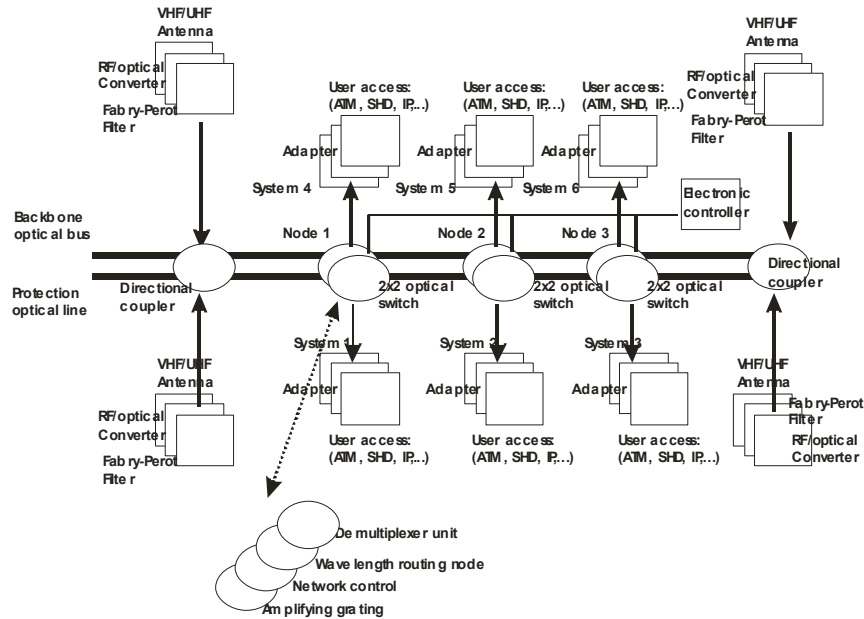

Figure 6: Architecture configuration with four antennas and six receiving systems applicable to multiple antenna scenarios. ( Node consists of amplifier grating, network control, wavelength routing, demultiplexer unit, and optical switching)

#### 3.1. Microwave/Optical Distribution Networks Employing RF Processing Methodology

In this architecture, only a single backbone optical bus cable is required for transporting the RF signals from multiple antennas to any receiving systems located on-board the aircraft shown in Figure 7. While the RF-multiplexer module is deployed for the purpose of combining the incoming VHF/UHF signals from these antennas, the RF/optical converter placed after the multiplexer injects these RF-signals in a single optical carrier over the optical bus. Most important, each node on the backbone fiber is capable of distributing or routing these RF signals to the receiving systems; however, since the routing process is only achieved in the RF domain, the design structure of these nodes turn out to be simple to implement. This indicates that a few components are required for achieving the construction of these nodes: directional coupler, optical/RF converter, RF splitter, and RF/optical converter, resulting in the node structure being less complicated in the RF domain. As shown, this solution has the advantage that after an optical signal is converted into the RF domain, it can be easily amplified at each node by means of an RF amplifier before carrying any RF signals to each system, thereby compensating for any signal loss directly caused by the use connectors and directional couplers on the optical bus. However, the drawback of this system is that since each node demands a number of transmitter and receiver modules, and as the number of nodes in the system increases, the signal to noise ratio for the overall system will be degraded.

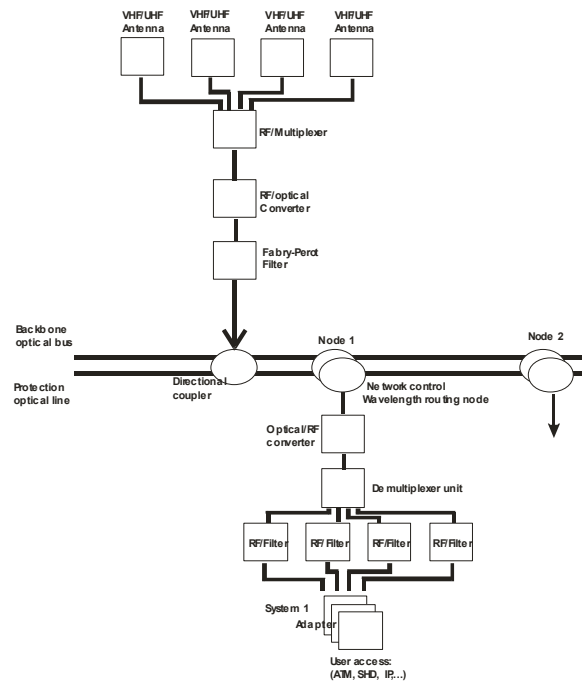

Figure 7: RF/Optical network depicts multiple antennas transporting signals to multiple systems. (Node consists of directional coupler, optical/RF converter, RF amplifier, and RF/optical converter)

### 3.2. Microwave/Optical Distribution Networks employing optical processing methodology

In order to explore the all-optical solutions for data distribution from multiple antennas (sources) to a number of systems, we will rely on the coarse wavelength division multiplexing technology in which a specific wavelength is optically modulated with each RF signal from its antenna, as shown in Figure 8. Although only one optical bus is used for data transmission, the other fiber will serve as the protection cable in case of accidental failure of the backbone. The basic operation of this architecture is that when the modulated RF signal is received from the antenna, it will be transformed into the optical domain using the RF/optical converter, before being coupled into the backbone optical bus. Consequently, each optical carrier will be specifically assigned to each RF signal from its antenna in the optical domain, i.e.,  $\lambda_1$  to RF1,  $\lambda_2$  to RF2, etc., where  $\lambda$  defines the optical wavelength of the laser and RF specifies the modulated signal of the receiving antenna. Since each of the systems will receive more than one wavelength, separation of wavelengths can be achieved simply by using a wavelength de-multiplexing unit. From each of the separated wavelengths, separate receivers (optical/RF converter) can be deployed at each system for retrieving separate RF signals transmitted by different antennas.

This approach has the advantage that the use of the WDM technique significantly increases the bandwidth capacity of optical systems, for the channel separation can be as narrow as 50 GHz apart with the data rate at 10 Gb/s or higher. While this architecture is emerging as a robust and economic solution for RF data distribution, it also possesses the ability to leverage conventional technology to make a jump to the next generation data rate. Additionally, since each node on the backbone fiber eliminates the use of the transceivers for optical and RF conversion, there will be significant reduction in the signal-to-noise ratio as compared to the RF processing methodology described in Section 2.1. Though another drawback of this solution is that since a large number of optical splitters are used for signal distribution from the backbone fiber to the user destinations, these splitters typically contribute to significant loss that could degrade the signal strength considerably. Moreover, WDM components tend to be costlier than a single wavelength system.

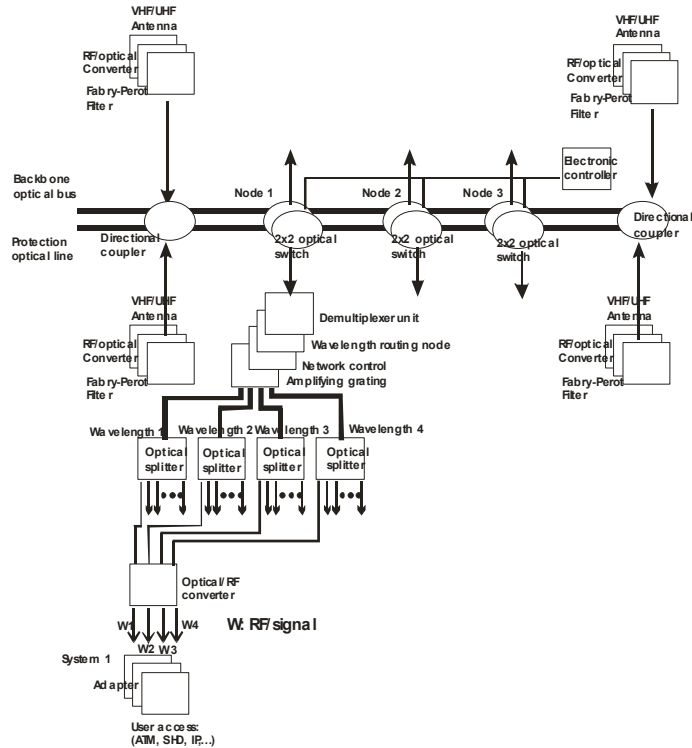

Figure 8: All-Optical network depicts multiple antennas transporting signals to multiple systems. (Node consists of optical switch, demultiplexer unit, wavelength routing module, network controller, grating amplifier )

#### 4. EXPERIMENTAL SETUP

Figure 9 illustrates the experimental setup for the first of two basic configurations described in Section 2. The basic WDM architecture supports two optical channels operating at wavelengths of 1310 and 1550 nm. The 1310 nm channel has an Ortel 3541C transmitter and an Ortel 4518A receiver. The frequency range of operation for these fiber optic devices is between 10 MHz and 10 GHz. Likewise, the 1550 nm channel has an Ortel 1741A transmitter and an Ortel 2516A receiver, which again operate between 10 MHz and 10 GHz. Next, RF signals were produced using the Fluke 6060B RF generator, which operates between 10 KHz and 1050 MHz, and the Agilent 8712 ET network analyzer, which operates between 10 and 1300 MHz. Thus, the highest frequency for which we have obtained measurements is 1300 MHz, which is in the UHF frequency range. The RF generator provided the capability of internal and external FM and AM modulation. It should be noted that optical signals at both 1310 and 1550 nm were continuously present throughout the following experiments to verify that there is no crosstalk between the signals in the WDM FOL.



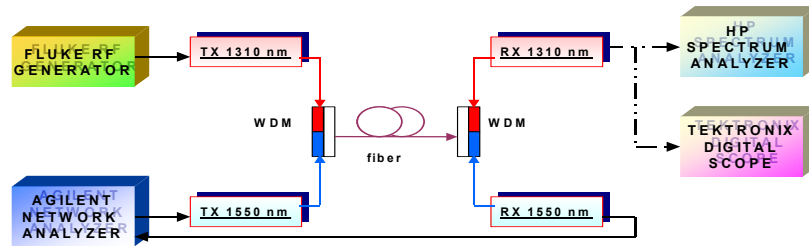

Figure 9: Set-up configuration of fiber optic distribution network for two wavelengths 1330 and 1550 nm based on wavelength division multiplexing approach.

From Figure 10 we can see that the SNR for AM and FM at 1310 nm is approximately 55 dB and at 1550 nm, is approximately 40 dB. These measurements suggest good analog signal transmission over WDM FOLs since they exceed the 30 dB standard for good AM radio reception [9].

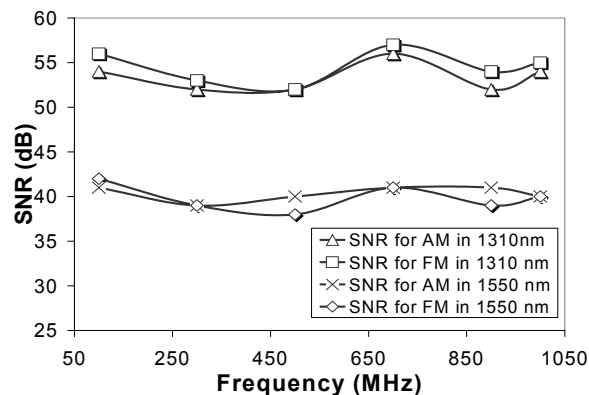

Figure 10: Measured signal-to-noise ratio in the VHF and near UHF frequency range for both AM and FM schemes with wavelengths at 1330 and 1550 nm.

## 5. CONCLUSION

In this paper, we presented two approaches for UVF/UHF data distribution in on-board aircraft from a single or multiple antennas. The first approach, addressing the issues of RF/optical distribution architecture employing RF processing methodology, is simple in both installation and maintenance aspects, and demands only one optical fiber that runs from the tail of the aircraft to the cockpit. However, since each node requires a transceiver unit for optical/RF conversion, the cost of the transceivers may become significantly high if a large number of nodes are need in the architecture. On the other hand, the second approach, focusing on all-optical passive networking architecture and employing optical processing methodology, has the advantage that no transceivers are required at the nodes in order to route the RF signal. While all the signal routing is done optically, use of an optical splitter not only allows the flexibility of rerouting between node and system, but also the simplicity of the network architecture which requires no electronic controllers or

RF converters. Finally, the measured results of the signal-to-noise ratio for two optical carriers at 1330 and 1550 nm using the WDM technique demonstrates the feasibility of implementing fiber optic link distribution networks in on-board aircraft which could replace the conventional electronic link distribution network.

## REFERENCES

- [1] Gee, C.M., Newberg, I.L., Thurmond, G.D., "X-band Fiber Links", *SPIE High Frequency Optical Communications*, **Vol. 716**, pp.64-68, 1989.
- [2] Fulvio, A., Federica, C., Eugenio, I., et al, "A Transparent, All-Optical, Metropolitan Network Experiment in Field Environment: The "prometeo" Self-Healing Ring", *Lightwave Technol.*, **Vol 15, no.12**, pp. 2206-2212, Dec. 1997.
- [3] Pan, J.J., "5-GHZ wide-band fiber-optic link", *IEEE/OSA Optical Fiber Communication Conference*, New Orleans, LA, February 1983.
- [4] Kerr, R.B. "Data communications management for the Boeing 777 aircraft", *AIAA/IEEE 14th Digital Avionics Systems Conference*, Cambridge, MA, 1995.
- [5] Murdock, J.K., Koeing, J.R., "Open Systems Avionics Network to Replace MIL-STD-1553", Proceeding of the AIAA/IEEE 19<sup>th</sup> Digital Avionics Systems Conference, Philadelphia, PA, 2000.
- [6] Gardner, R.D., Andonovic, I., Hunter, D.K., McLaughlin, A.J., Aitchison, J.S., Marsh, J.H., "PHONAV-a photonic WDM network architecture for next generation avionics systems", Proceedings 1999 IEEE Aerospace Conference, Vol. 2, 1999.
- [7] Cohn, M.D., "A network architecture for advanced aircraft", Proceedings 14th Conference on Local Computer Networks, pp. 358 -364, 1989
- [8] Jian-Guo Zhang, "Broadband integrated digital information exchange networks for avionics applications", *IEEE Aerospace and Electronic Systems Magazine*, **Vol. 13 Issue: 11** , pp. 31-35, November 1998.
- [9] Wilgus, J.S., Beranek, M.W., Chan, E.Y., Hager, H.E., and Le, Q.N., "Potential opportunities for utilizing commercial optoelectronics in avionics fiber-optic network" , Proceedings of 18th Digital Avionics Systems Conference, Vol. 1-section 17, pp. 24-29, Oct. 1999.
- [10] Harres, D.N., "Using statistical methods to predict link quality in COTS-based fiber optic networks " *The 20th Conference on Digital Avionics Systems (DASC)*, **Vol. 1**, pp. 4D3/1-8, 2001.
- [11] Glass, M.; "Fibre Channel: leveraging a commercial networking technology for military applications", Proceedings of 18th Digital Avionics Systems Conference, pp. 3.A Vol. 1-section 17,.3/1 -14.1999.